

1352

Gate valves
Isomorphous series
PN 2,5-10 DN 40-600

Design
 Acc. to DIN 3352

Top part
 Outside screw
 Non-rising handwheel
 Rising stem
 Up to DN 150 one-piece bonnet

Obturator
 Double disk

Body seat
 Integral seats

Valve ends
 Flanges acc. to
 EN 1092-1 (DIN 2501
 Part 1)

Requirements and tests
 Acc. to DIN 3352 Part 1

Marking
 Nominal size DN
 Nominal pressure PN
 Body material
 Manufacturer brand

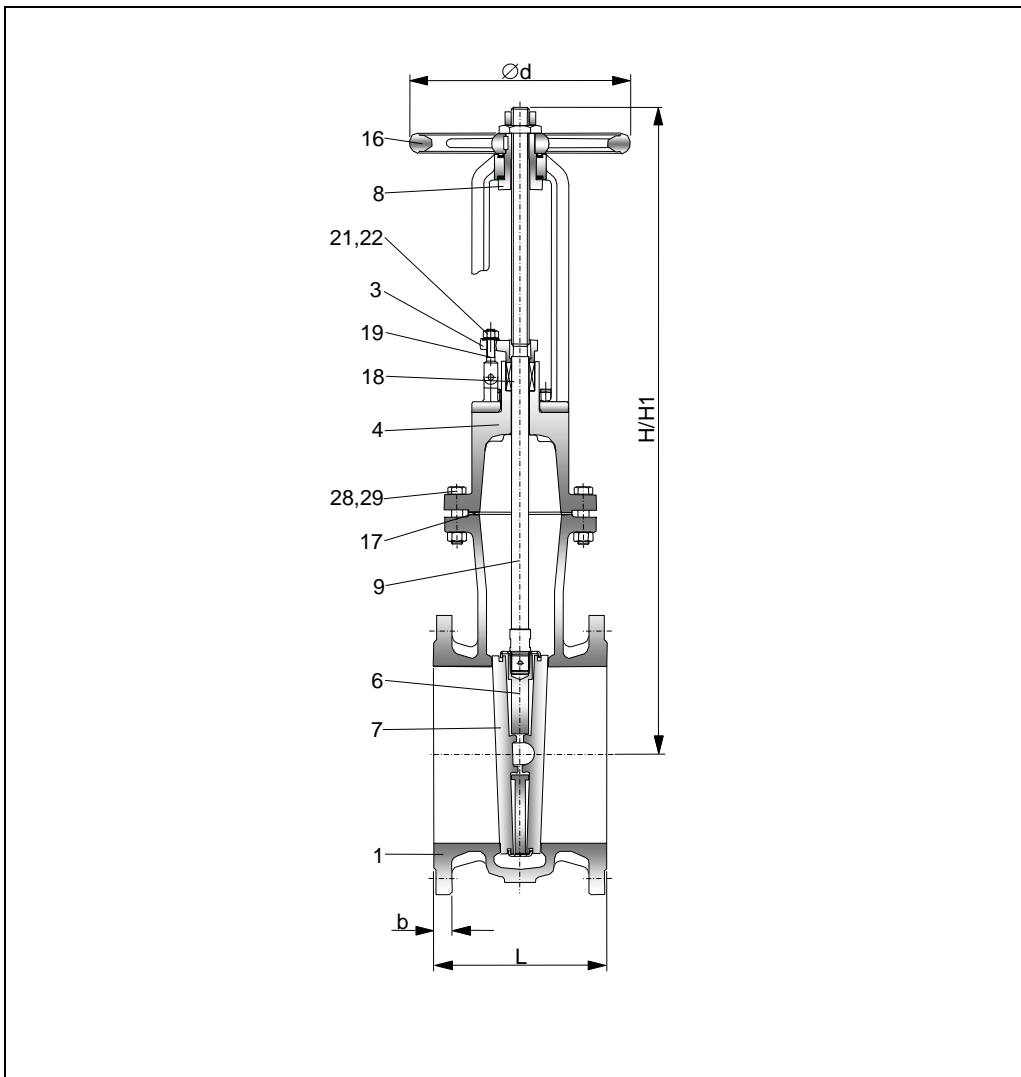

Pos.	Denomination	Material		Pos.	Denomination	Material	
		1.4308	1.4408			1.4308	1.4408
1	Body	1.4308	1.4408	17	Gasket	Graphite / 1.4401	Graphite / 1.4401
2	Yoke	1.4308	1.4408	18	Packing	Graphite	Graphite
3	Gland	1.4541	1.4571	19	Stud bolts	A2-70	A4-70
4	Bonnet	1.4308	1.4408	21	Washer	1.4541	1.4571
6	Support	1.4308	1.4408	22	Hex. Nut	A2	A4
7	Sealing plates	1.4541	1.4571	28	Stud bolts	A2-70	A4-70
8	Sleeve	0.7040	0.7040	29	Hex. Nuts	A2	A4
9	Stem	1.4541	1.4571				
16	Handwheel	Steel	Steel				

¹ further materials are shown in the technical part

Face-to-face dimensions acc. to EN 558 series 14 (DIN 3202-F4)

PN	10							6			4			2,5
DN	40	50	65	80	100	125	150	200	250	300	350	400	500	600
L	140	150	170	180	190	200	210	230	250	270	290	310	350	390
H	270	300	320	395	445	525	580	780	870	1005	1255	1330	1610	1840
H1	315	395	395	485	555	660	735	990	1135	1320	1620	1745	2130	2465
d	140	140	160	160	180	200	200	225	280	320	360	360	500	720
b														
PN10	18	20	18	20	20	22	22	24	26	28	30	32	36	40
kg														

Pressure/Temperature ratings in bar g at Temperature in °C

Material	PN	50°C	100°C	120°C	150°C	200°C	250°C	300°C					
»1.4308« GX5CrNi19-10 EN 10213	2,5	2,5	1,9	1,9	1,6	1,4	1,3	1,2					
	4	4,0	3,0	3,0	2,6	2,2	2,1	1,9					
	6	6,0	4,6	4,6	4,0	3,4	3,1	2,9					
	10	10,0	7,7	7,7	6,7	5,7	5,2	4,8					
»1.4408« GX6CrNiMo18-10-2 EN 10213	2,5	2,5	2,0	2,0	1,8	1,5	1,4	1,2					
	4	4,0	3,3	3,3	2,9	2,5	2,2	2,0					
	6	6,0	4,9	4,9	4,3	3,7	3,4	3,0					
	10	10,0	8,2	8,2	7,2	6,2	5,7	5,1					

Modifications

Spring loaded stuffing box
Extended bonnet for sub-zero
applications

Additional equipment

Chain wheel
Stem extension
Electric actuator

Installation

Piping is to be in such a manner that injurious thrust and bending forces are kept away from the valve casings. Gate valves are usually installed with vertical stem position. Gate valves can also be installed in pipelines with changing flow directions. If in the closed position the medium between the obturator and the middle area of the body can be heated up, the user has to check if a cavity pressure relief must be used. In this case e.g. a relief valve will be installed via tube to the inlet side of the gate valve (defined flow direction).
When turning the handwheel it is not allowed to use additional levers.