

1403

Gate valves
Flexible wedge

PN 10 - 25 DN 50 - 600

Design

Acc. to DIN 3352

Top part

Outside screw
Non-rising handwheel
Rising stem
Up to DN 125 one-piece bonnet

Obturator

Flexible wedge

Body seat

Integral seats
min. 13% Cr

Valve ends

Flanges acc. to
EN 1092-1 (DIN 2501
Part 1)

Requirements and tests

Acc. to DIN 3352 Part 1

Marking

Nominal size DN
Nominal pressure PN
Body material
Manufacturer brand

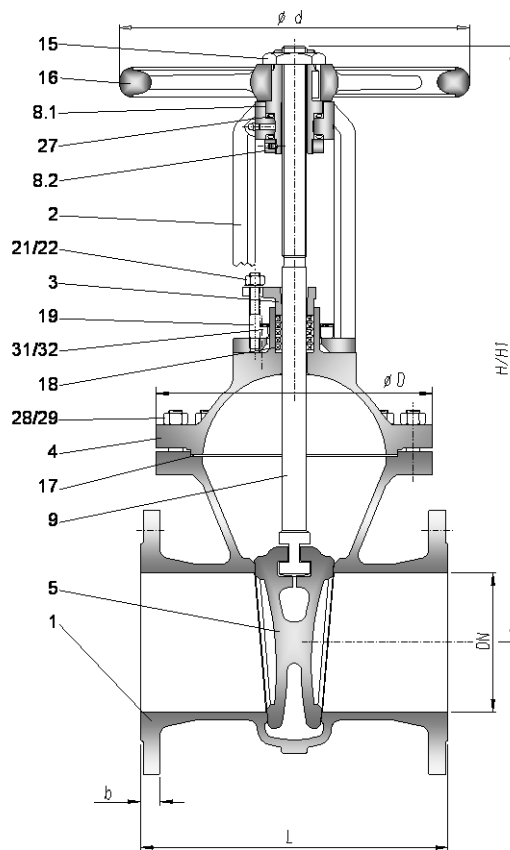

Pos.	Denomination	Material		Pos.	Denomination	Material	
		1.0619	1.7221			1.0619	1.7221
1	Body	1.0619	1.7221	17	Gasket (grooved)	1.4541 / Graphite	1.4541 / Graphite
2	Yoke	1.0619	1.7221	18	Packing	Graphite	Graphite
3	Gland	1.0619	1.7221	19	Stud bolt	1.7218	A2-70
4	Bonnet	1.0619	1.7221	21	Washer	Stahl	1.4541
5	Wedge	1.4027	1.4308	22	Hex. Nut	1.1181	A2
8.1	Sleeve	0.7040	0.7040	27	Bearing	Cr.-steel	Cr.-steel
8.2	Threaded ring	1.4021	1.4021	28	Stud bolt	1.7218	A2-70
9	Stem	1.4021	1.4541	29	Hex. Nut	1.1181	A2
15	Retaining nut	Steel, zinc-coated		31	Stud bolt	1.7218	A2-70
16	Handwheel	Steel	Steel	32	Hex. Nut	1.1181	A2

¹ further materials are shown in the technical part

Face-to-face dimensions acc. to EN 558 series 15 (DIN 3202-F5)

DN	50	65	80	100	125	150	200	250	300	350	400	500	600
L	250	270	280	300	325	350	400	450	500	550	600	700	800
H	325	365	405	475	560	645	800	945	1130	1280	1385	1775	2025
H ₁	390	445	505	595	710	820	1025	1220	1460	1655	1815	2310	2665
$\varnothing d$	200	225	225	320	360	400	400	500	500	500	640	720	800
$\varnothing D$	178	182	215	255	272	315	365	440	515	580	615	750	850
PN 10	b	18	18	20	20	22	22	24	26	28	30	32	36
	kg												
PN 16	b	20	18	20	20	22	22	24	26	28	30	32	36
	kg												
PN 25	b	20	22	24	24	26	28	30	32	34	38	40	44
	kg												

Pressure/Temperature ratings in bar g at Temperature in °C

Material	PN	50°C	100°C	120°C	150°C	200°C	250°C	300°C	350°C	400°C			
»1.0619« GP240GH EN 10213	10	10,0	8,7	8,7	8,0	7,2	6,6	6,0	5,6	5,4			
	16	16,0	14,0	14,0	12,8	11,6	10,6	9,6	9,0	8,6			
	25	25,0	21,8	21,8	20,0	18,2	16,6	15,1	14,0	13,5			
»1.7221« GS-26CrMo4 SEW685/AD-W10	10	10,0	9,1	8,8	8,3	8,1	7,9	7,5					
	16	16,0	14,6	14,1	13,3	13,0	12,6	12,0					
	25	25,0	22,9	22,0	20,8	20,3	19,7	18,7					

Modifications

Position Indicator
Butt-welding ends
Pressure relieve
By-pass tube
Spring loaded stuffing box

Additional equipment

Chain wheel
Stem extension
Gear
Electric actuator

Installation

Piping is to be in such a manner that injurious thrust and bending forces are kept away from the valve casings. Gate valves are usually installed with vertical stem position. Gate valves can also be installed in pipelines with changing flow directions. If in the closed position the medium between the obturator and the middle area of the body can be heated up, the user has to check if a cavity pressure relief must be used. In this case e.g. a relief valve will be installed via tube to the inlet side of the gate valve (defined flow direction).

When turning the handwheel it is not allowed to use additional levers.

1403

Gate valves

Flexible wedge

PN 10 - 25 DN 50 - 600

Design

Acc. to DIN 3352

Top part

Outside screw
Non-rising handwheel
Rising stem
Up to DN 125 one-piece bonnet

Obturator

Flexible wedge

Body seat

Integral seats

Valve ends

Flanges acc. to
EN 1092-1 (DIN 2501
Part 1)

Requirements and tests

Acc. to DIN 3352 Part 1

Marking

Nominal size DN
Nominal pressure PN
Body material
Manufacturer brand

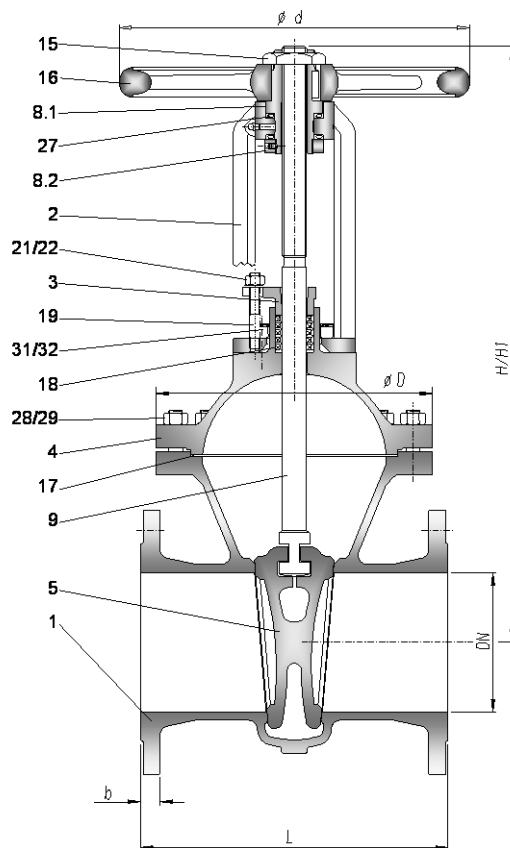

Pos.	Denomination	Material		Pos.	Denomination	Material	
		1.4308	1.4408			1.4308	1.4408
1	Body	1.4308	1.4408	17	Gasket (grooved)	1.4541 / Graphite	1.4571 / Graphite
2	Yoke	1.4308	1.4408	18	Packing	Graphite	Graphite
3	Gland	1.4541	1.4571	19	Stud bolt	A2-70	A4-70
4	Bonnet	1.4308	1.4408	21	Washer	1.4541	1.4571
5	Wedge	1.4308	1.4408	22	Hex. Nut	A2	A4
8.1	Sleeve	0.7040	0.7040	27	Bearing	Cr.-steel	Cr.-steel
8.2	Threaded ring	1.4021	1.4021	28	Stud bolt	A2-70	A4-70
9	Stem	1.4541	1.4571	29	Hex. Nut	A2	A4
15	Retaining nut	Steel, zinc-coated		31	Stud bolt	A2-70	A4-70
16	Handwheel	Steel	Steel	32	Hex. nut	A2	A4

¹ further materials are shown in the technical part

Face-to-face dimensions acc. to EN 558 series 15 (DIN 3202-F5)

DN	50	65	80	100	125	150	200	250	300	350	400	500	600
L	250	270	280	300	325	350	400	450	500	550	600	700	800
H	325	365	405	475	560	645	800	945	1130	1280	1385	1775	2025
H1	390	445	505	595	710	820	1025	1220	1460	1655	1815	2310	2665
Ø d	200	225	225	320	360	400	400	500	500	500	640	720	800
Ø D	178	182	215	255	272	315	365	440	515	580	615	750	850
PN 10	b	18	18	20	20	22	22	24	26	28	30	32	36
	kg												
PN 16	b	20	18	20	20	22	22	24	26	28	30	32	36
	kg												
PN 25	b	20	22	24	24	26	28	30	32	34	38	40	44
	kg												

Pressure/Temperature ratings in bar g at Temperature in °C

Material	PN	50°C	120°C	150°C	200°C	250°C	300°C						
»1.4308« GX5CrNi19-10 EN 10213	10	10,0	7,7	6,7	5,7	5,2	4,8						
	16	16,0	12,3	10,7	9,1	8,4	7,7						
	25	25,0	19,2	16,7	14,2	13,1	12,1						
»1.4408« GX6CrNiMo18-10-2 EN 10213	10	10,0	8,2	7,2	6,2	5,7	5,1						
	16	16,0	13,2	11,6	10,0	9,1	8,2						
	25	25,0	20,7	18,1	15,7	14,2	12,8						

Modifications

Position indicator
 Extended bonnet
 Butt-welding ends
 Pressure relief
 By-pass tube
 Spring loaded stuffing box

Additional equipment

Chain wheel
 Stem extension
 Gear
 Electric actuator

Installation

Piping is to be in such a manner that injurious thrust and bending forces are kept away from the valve casings. Gate valves are usually installed with vertical stem position. Gate valves can also be installed in pipelines with changing flow directions. If in the closed position the medium between the obturator and the middle area of the body can be heated up, the user has to check if a cavity pressure relief must be used. In this case e.g. a relief valve will be installed via tube to the inlet side of the gate valve (defined flow direction).

When turning the handwheel it is not allowed to use additional levers.