

DSP-2C



SINGLE VOLUTE TWIN SCREW PUMP SERIES DSP-2C

WITH SHAFT SEALING
ACC. TO API 676 3rd Edition



TWIN SCREW PUMP SERIES DSP-2C ACC. API 676 3RD EDITION



Klaus Union supplies magnetic coupled twin screw pumps for more than 25 years.

For demanding applications with mechanical seals Klaus Union offers a series of twin screw pumps, the DSP-2C complementing our well known DSP-4C and magnet driven SLM DSP-2C twin screw pump ranges.

The mechanical sealed twin screw pumps DSP-2C are engineered following API 676 3rd Edition regulations and offer the usual Klaus Union Twin screw pump features such as rugged design, maintenance friendly „PLUG & PUMP“ Cartridge Design as well as high quality casted casings of carbon steel, stainless steel or even higher grade materials.

The pumps are designed to accept standard cartridge seals (fully interchangeable with centrifugal pump seals) to reduce spare parts and stock costs for customers, as well as to ensure fast availability of spare mechanical seals all over the world. If requested by the customer the pumps can also accept fully API 682 compliant mechanical seals.

Alternatively the standardized gland area makes it easy to install gland packing or lip seal arrangements.

The optional available pressure limiting valve (PLV) using Klaus Union valve product line proven design and internals can protect the pump hydraulic against overpressure and is executed with return to suction as a standard. If requested the pump casings are executed with connection to directly mount standard API 526 grade safety valves on them.

Experience
Responsibility
Passion



Quality Assurance

A major component of the Klaus Union ethos is to ensure highest product quality. Existing quality assurance procedures with Klaus Union suppliers are constantly monitored from order placement to goods receipt and final assembly. This quality assurance system, developed on latest technologies, complies with the requirements of international regulations.

Klaus Union is a DIN EN ISO 9001 certified company



In accordance with
TÜV NORD CERT
procedures,

KLAUS UNION GmbH & Co. KG
Blumenfeldstraße 18, 44795 Bochum
&
KLAUS UNION Service GmbH & Co. KG
Blumenfeldstraße 18, 44795 Bochum

are certified according to
DIN EN ISO 9001

Performance Range

- ▶ **Flow Rate:** Q = up to 1.800 m³/h
- ▶ **Diff. Pressure:** ΔP = up to 40 bar

Higher flow rates upon request

Pressure Ratings/Temperature Range

- ▶ **Standard Construction:** PN 25 at 120 °C
- ▶ **Temperature Range:** -120 °C up to 350 °C
- ▶ **Pressure Rating:** up to PN 400



DESIGN DETAILS

DSP-2C

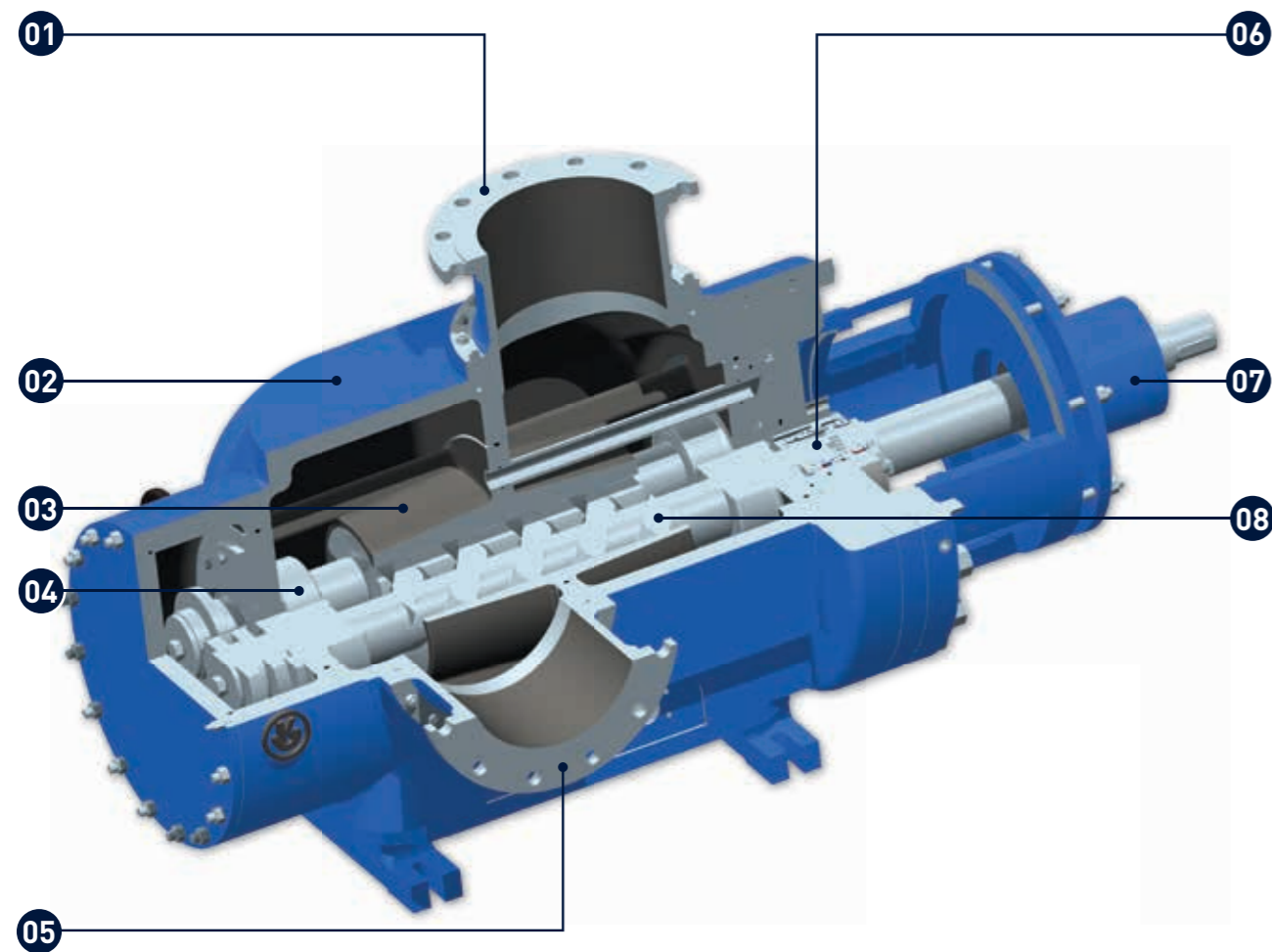

The description
can be found on the
following page
→

Design According to API 676 3rd Edition

- 01 ▶ **Adaptable Discharge Casing**
to fit project requirements for nominal diameter, rating and execution. Engineered for smooth flow.
- 02 ▶ **Middle Casing**
with high Liquid Retention for Stripping Pumps. Radial Split casing with foot or centerline mounting to provide maximum flexibility for customer interfaces. Designed to PN 25 at 120 °C.
- 03 ▶ **Casted Casing Insert (Liner)**
in Heavy Duty Design.
- 04 ▶ **Radial Slide Bearings**
optimized to meet customer application needs for maximum overall pump lifetime. Designed acc. to decades of experience in supplying heavy duty pumps with slide bearings.
- 05 ▶ **Adaptable Suction Casing**
to fit Project Requirements for Nominal Diameter, Rating and Execution. Engineered for Low Inlet Losses.
- 06 ▶ **Cartridge Mechanical Seal**
with seal chamber compliant with ANSI B73.1 / API 610 / API 682, subjected only to inlet pressure as a standard.
- 07 ▶ **Bearing Carrier**
with high performance bearings following API 676 3rd Edition recommendations. Bearings available grease lubricated (both lifetime greased or regreaseable) as well as oil lubricated as per customer preferences.
- 08 ▶ **Pump Screws**
from single piece bar stock, low pulsating design with optimized screw profile for minimized power consumption.

KLAUS UNION TECHNOLOGY AND INNOVATION



Performance Data	
Flow Rate	max. 1.800 m³/h
Differential Pressure	max. 40 bar
Viscosity	max. 100.000 mm²/s (cSt)
Temperature	max. 350°C (662°F)

Higher flow rates upon request

Construction Material	
Pump Casing	Cast Carbon Steel 1.0619 (similar to A216WCB) Cast Stainless Steel 1.4408 (similar to A351 CF8M) Duplex Stainless Steel 1.4470 (A 890 4A / UNS J92205) Super Duplex Stainless Steel 1.4469 (A 890 / UNS J93372)
Liner	Cast Carbon Steel 1.0619 (similar to A216WCB) Cast Stainless Steel 1.4408 (similar A351 CF8M) Duplex Stainless Steel 1.4470 (A 890 4A / UNS J92205) Super Duplex Stainless Steel 1.4469 (A 890 / UNS J93372) Wear Resistant Coating
Screws	Carbon Steel 1.8550, nitrated Stainless Steel 1.4542 (similar to UNS S17400), hardened Duplex Stainless Steel 1.4462 (A182-F51 / UNS S31603), hardened Martensitic Stainless Steel 1.4122, nitrated Wear Resistant Coating
Shaft Seals	Standard Cartridge Seals depending on the actual operating conditions following ANSI B73.1 / API 610 / API 682

Upon request, Klaus Union Screw Pumps, Series DSP-2C, can be supplied also in Hastelloy, Inconel, other high nickle alloys or Titanium.

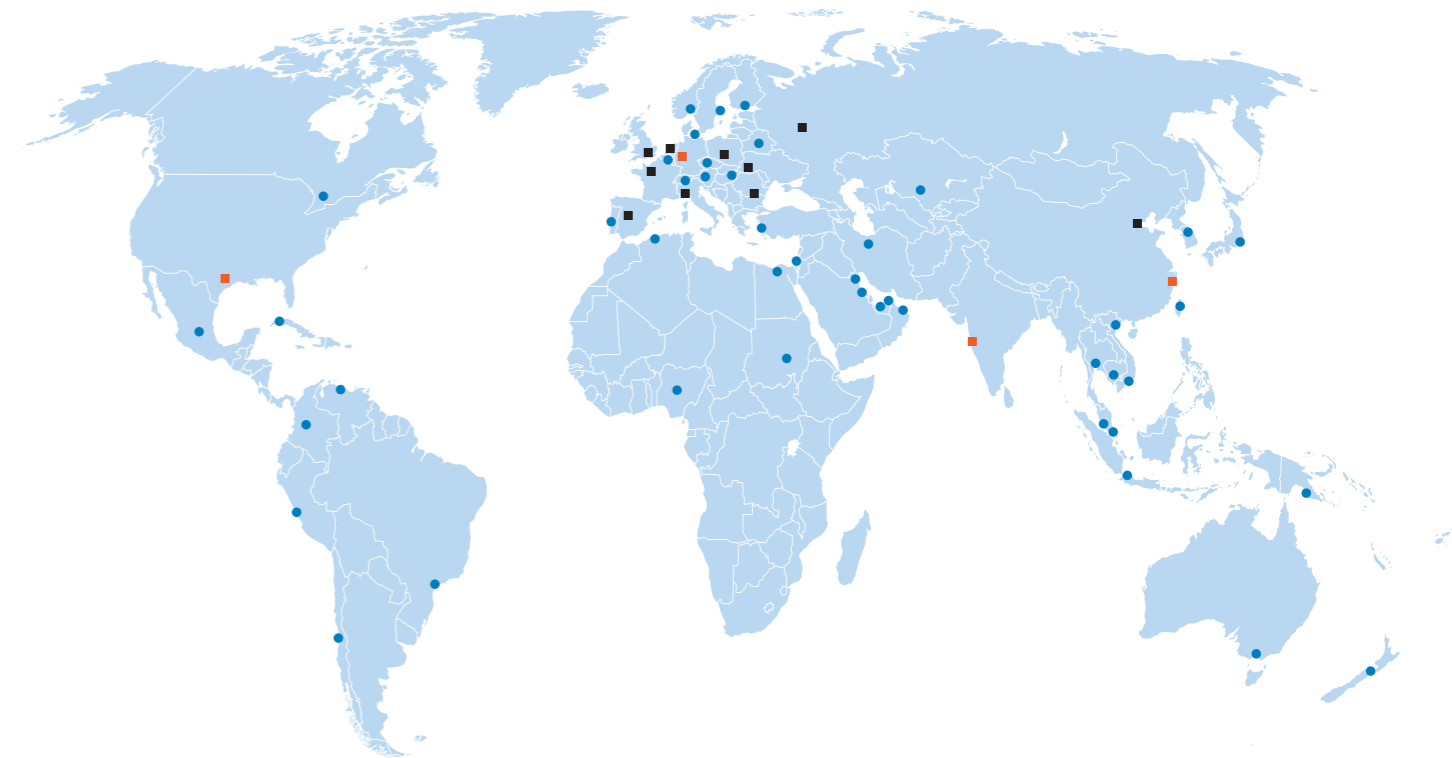

- Germany, Bochum
 - India, Pune
 - China, Ningbo
 - USA, Houston
 - England
 - France
 - Italy
 - The Netherlands
 - Poland
 - Romania
 - Russia
 - Spain
 - Ukraine
 - Algeria
 - Australia
 - Austria
 - Belarus
 - Belgium
 - Brazil
 - Cambodia
 - Canada
 - Chile
 - Colombia
 - Cuba
 - Czech Republic
 - Denmark
 - Egypt
 - Finland
 - Hungary
 - Indonesia
 - Iran
 - Iraq
 - Israel
 - Japan
 - Kazakhstan
 - Kuwait
 - Malaysia
 - Mexico
 - New Zealand
 - Nigeria
 - Norway
 - Oman
 - Papua New Guinea
 - Peru
 - Portugal
 - Saudi Arabia
 - Singapore
 - Slovakia
 - South Korea
 - Sudan
 - Sweden
 - Switzerland
 - Taiwan
 - Thailand
 - Turkey
 - UAE / Abu Dhabi
 - UAE / Dubai
 - Venezuela
 - Vietnam
- Klaus Union Center of Competence
 ■ Klaus Union Subsidiary
 ● Klaus Union Sales Office

Product Range Pumps:

Pumps with Magnet Drive

- ▶ Centrifugal Pumps acc. to DIN EN ISO 2858 & DIN EN ISO 15783, SLM NV
- ▶ Centrifugal Pumps acc. to ASME B73.3M, SLM AV
- ▶ Centrifugal Pumps for Petrochemical Applications acc. to API 685, SLM APL / SLM APC
- ▶ Centrifugal Pumps for High Pressure Applications, SLM SV/SLM GV
- ▶ Centrifugal Pumps for High Temperature Applications, SLM NHO
- ▶ Self-Priming Centrifugal Pumps, SLM SV
- ▶ Multi-Stage Centrifugal Pumps, Tension-Rod or Barrel-Type Design, SLM GV
- ▶ Submerged Centrifugal Pumps, SLM NVT
- ▶ Twin Screw Pumps acc. API 676, SLM DSP-2C

Pumps with Shaft Sealing

- ▶ Centrifugal Pumps acc. to DIN EN ISO 2858 & DIN EN ISO 5199, NOV
- ▶ Multi-Stage Centrifugal Pumps, Tension-Rod or Barrel-Type Design, GOV / GOVT
- ▶ Horizontal and Vertical Propeller Pumps, P
- ▶ Bottom-Flange Propeller Pumps, UP
- ▶ Submerged Centrifugal Pumps, TP NO
- ▶ Submerged, Multi-Stage Centrifugal Pumps, TP GO
- ▶ Twin Screw Pumps acc. API 676, DSP-2C / DSP-4C

Product Range Valves:

- ▶ Globe Valves, T
- ▶ Globe Valves, Y
- ▶ Gate Valves, Isomorphous Construction Series
- ▶ Gate Valves, Wedge or Wedge Plates
- ▶ Relief Valves
- ▶ Check Valves
- ▶ Sight Glasses
- ▶ Strainers
- ▶ Filters
- ▶ Bottom Valves
- ▶ Safety Valves

Klaus Union Service Performance:

- ▶ Workshop / On-Site Repairs
- ▶ Genuine Spare Part Delivery Worldwide
- ▶ Spare Parts Storage
- ▶ Customized Spare Parts Management
- ▶ On-Site Maintenance
- ▶ Installation
- ▶ Retrofitting
- ▶ On-Site Testing / Monitoring
- ▶ Customer Advisory Service
- ▶ Start Up & Commissioning
- ▶ Individual 24 / 7-Service
- ▶ Trouble-Shooting
- ▶ In-House & On-Site Training
- ▶ On-Site Assembly and Disassembly
- ▶ Long-Term Maintenance Contracts
- ▶ Maintenance Planning and Consulting
- ▶ Diagnostics

Klaus Union GmbH & Co. KG

Blumenfeldstraße 18 | 44795 Bochum | Germany

Phone: +49 (0) 234 4595-0 | Fax: +49 (0) 234 4595-7000 | E-Mail: info@klaus-union.com

www.klaus-union.com